

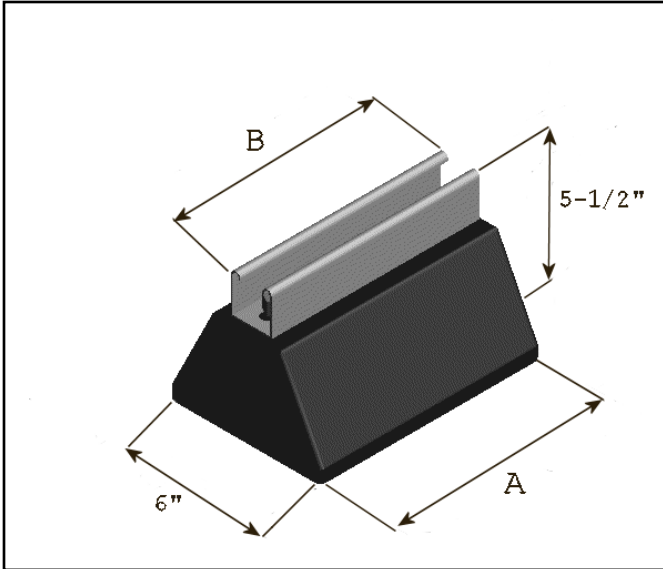

# REC-S

## Rubber EcoCurb with Strut

# Specification Sheet



**REC-S – Rubber EcoCurb Support with Strut** – Is designed specifically for use on rooftop without adhesive, roof penetrations, flashings or damage to roofing system. Utilized to support conduit or pipe sizes up to Ø 8". Strut is bolted directly to EcoCurb support by 1/2" X 3-1/2" Bolts, 1/2" Nuts and Washers. Strut clamps are suggested to hold piping.



### Materials

**EcoCurb:** Manufactured from Recycled Rubber, Vulcanized.

**LEED:** 100% recycled pre-consumer rubber

**EcoCurb Dimensions:** 4" high X 6" wide, in length of 9" or 13"

**Frame:** 1-5/8" X 1-5/8" 12 ga. channel (ASTM A653) - available in Pre-Galvanized Zinc coated, Hot-Dip Galvanized or Stainless Steel finishes.

**Hardware:** 1/2" X 3-1/2" Bolts; 1/2" Nuts and Washers available in Pre-Galvanized Zinc coated, Hot-Dip Galvanized or Stainless Steel finishes.

**Accessories:** Strut Clamps; Protection Pads

Model	Dimensions		Weight
	A	B	
REC9S	9"/22.86cm	8"/20.32cm	9-1/2 lb/4.31kg
REC13S	13"/33.02cm	12"/30.48cm	13 lb/5.90kg
REC1609S	9"/22.86cm	16"/40.64cm	10-1/2 lb/4.76kg
REC2413S	13"/33.02cm	24"/60.96cm	14 lb/6.35kg

### Installation:

- Verify that roof surface is smooth and clean to extent needed to receive materials.
- Review approved final drawings to determine the locations of EcoCurb Supports.
- Clean surfaces to receive EcoCurb Supports removing any loose gravel and any foreign matter before setting EcoCurb Supports.
- Accurately locate and align pre-fabricated EcoCurb supports in locations specified as per approved shop drawings or as required herein and by site conditions to limit pipe and/or conduit deflection to L/240, not to exceed 10' (3m) on center. If Isolation pads are required, place under each EcoCurb Support.
- Should the roofing manufacturer require a separation sheet between the roof and the EcoCurb Support, place a separation sheet or protective pad conforming to the existing roof manufacturer's system under each EcoCurb Support. Do not adhere to the roof system or to EcoCurb Support.
- Repeat until all supports supplied are installed in accordance with approved shop drawings.
- Remove any unused materials and packaging from job site.

This print/image and design and detail shown hereon is the property of Advanced Support Products, Inc. This print is furnished with the understanding that it is not to be reproduced without permission, and must be returned upon demand. All rights of design and invention are reserved by Advanced Support Products.

Patents #5816554 ; #6229497; #6427965; #6448497; #6578827 © 2010