



ADVANCED SUPPORT PRODUCTS, INC.

SS1000R — Pipe Support

Pipe Support with Roller

Specification Sheet

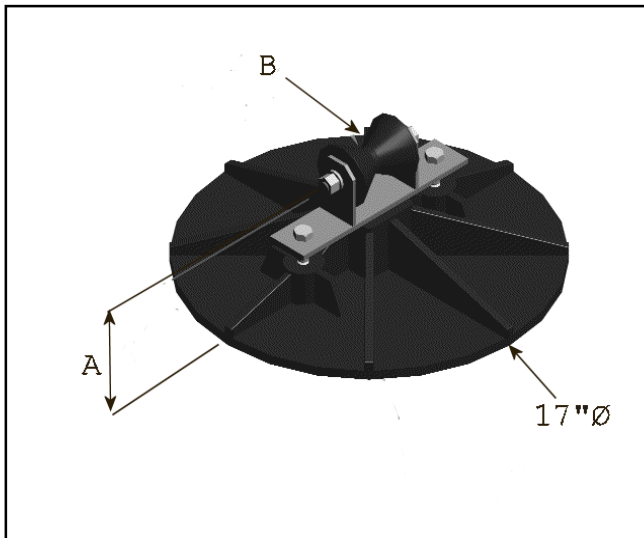

SS1000R – Pipe Support with Roller – Is designed specifically for use on rooftop without adhesive, roof penetrations, flashings or damage to roofing system. Designed to support conduit or pipe up to $\varnothing 4"$. Roller mechanism allows for pipe movement. Weight disbursed over 227 sq. in. per support.



Materials

Support Base: 17" circular base, injected molded polypropylene, with 227 sq. in. of surface on bottom, designed for weight displacement.

Base Dimensions: 3"H X 17" in diameter, designed for weight displacement, with molded insert for square tubing and two threaded rod couplings molded in.

LEED: Minimum 40 % post industrial recycled polypropylene with UV inhibitors.

Roller Frame: Hot-Dip Galvanized Steel

Hardware: 1/2" X 2-1/2" Bolts with 1/2" Nuts and Washers; Roller uses 1/2" X 5-1/2" Bolts with 1/2" Nuts and Washers, available in Pre-Galvanized Zinc coated, Hot-Dip Galvanized or Stainless Steel finishes.

Accessories: Protection Pads

Model	Dimensions		Weight
	A	B	
SS1000R	6-1/4"/15.88cm	4"/10.20cm	7-1/2 lb/3.40 kg

Installation:

- Verify that roof surface is smooth and clean to extent needed to receive materials.
- Review approved final drawings to determine the locations of supports.
- Clean surfaces to receive supports removing any loose gravel and any foreign matter before setting support 17" circular bases.
- Accurately locate and align pre-fabricated pipe supports in locations specified as per approved shop drawings or as required herein and by site conditions to limit pipe and/or conduit deflection to L/240, not to exceed 10' (3m) on center. No Isolation pads are required under the 17" circular bases.
- Should the roofing manufacturer require a separation sheet between the roof and the support system, place a separation sheet or protective pad conforming to the existing roof manufacturer's system under 17" circular bases. Do not adhere to the roof system or 17" circular bases.
- Repeat until all supports supplied are installed in accordance with approved shop drawings.
- Remove any unused materials and packaging from job site.

This print/image and design and detail shown hereon is the property of Advanced Support Products, Inc. This print is furnished with the understanding that it is not to be reproduced without permission, and must be returned upon demand. All rights of design and invention are reserved by Advanced Support Products. Patents #5816554; #6229497; #6427965; #6448497; #6578827 © 2010