



ADVANCED SUPPORT PRODUCTS, INC.

# SS1000RA

## Pipe Support with Adjustable Roller

## Specification Sheet

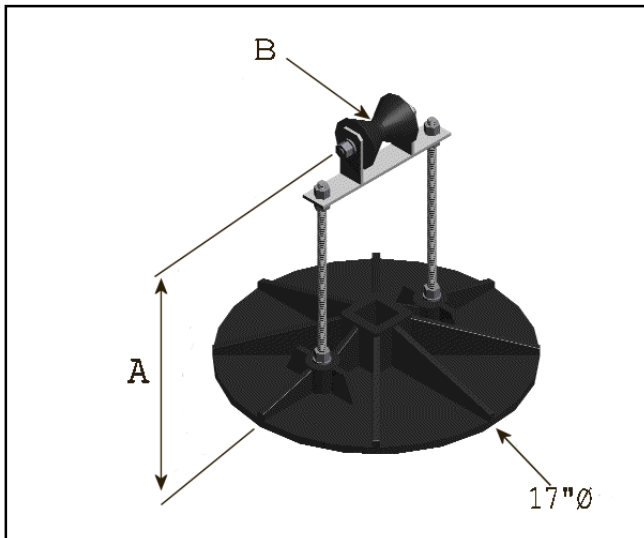

**SS1000RA – Pipe Support with Adjustable Roller** – Is designed specifically for use on rooftop without adhesive, roof penetrations, flashings or damage to roofing system. Designed to support conduit or pipe up to  $\varnothing 4"$ . Height of roller mechanism can be adjustable along the length of the 12" threaded rods. Weight disbursed over 227 sq. in. per support.



### Materials

**Support Base:** 17" circular base, injected molded polypropylene, with 227 sq. in. of surface on bottom, designed for weight displacement.

**Base Dimensions:** 3"H X 17" in diameter, designed for weight displacement, with molded insert for square tubing and two threaded rod couplings molded in.

**LEED:** Minimum 40 % post industrial recycled polypropylene with UV inhibitors.

**Roller:** 4" SRB Plastic Roller

**Roller Frame:** Hot-Dip Galvanized Steel

**Hardware:** 1/2" Threaded Rods (12" high) with 1/2" Nuts & Washers; Roller uses 1/2" X 5-1/2" Bolt with 1/2" Nuts & Washers available in Pre-Galvanized Zinc coated, Hot-Dip Galvanized or Stainless Steel finishes.

**Accessories:** Protection Pads

| Model    | Dimensions      |            | Weight        |
|----------|-----------------|------------|---------------|
|          | A               | B          |               |
| SS1000RA | 14-1/2"/36.83cm | 4"/10.20cm | 12 lb/5.44 kg |

### Installation:

- Verify that roof surface is smooth and clean to extent needed to receive materials.
- Review approved final drawings to determine the locations of supports.
- Clean surfaces to receive supports removing any loose gravel and any foreign matter before setting support 17" circular bases.
- Accurately locate and align pre-fabricated pipe supports in locations specified as per approved shop drawings or as required herein and by site conditions to limit pipe and/or conduit deflection to L/240, not to exceed 10' (3m) on center. No Isolation pads are required under the 17" circular bases.
- Should the roofing manufacturer require a separation sheet between the roof and the support system, place a separation sheet or protective pad conforming to the existing roof manufacturer's system under 17" circular bases. Do not adhere to the roof system or 17" circular bases.
- Repeat until all supports supplied are installed in accordance with approved shop drawings.
- Remove any unused materials and packaging from job site.

This print/image and design and detail shown hereon is the property of Advanced Support Products, Inc. This print is furnished with the understanding that it is not to be reproduced without permission, and must be returned upon demand. All rights of design and invention are reserved by Advanced Support Products. Patents #5816554; #6229497; #6427965; #6448497; #6578827 © 2010