

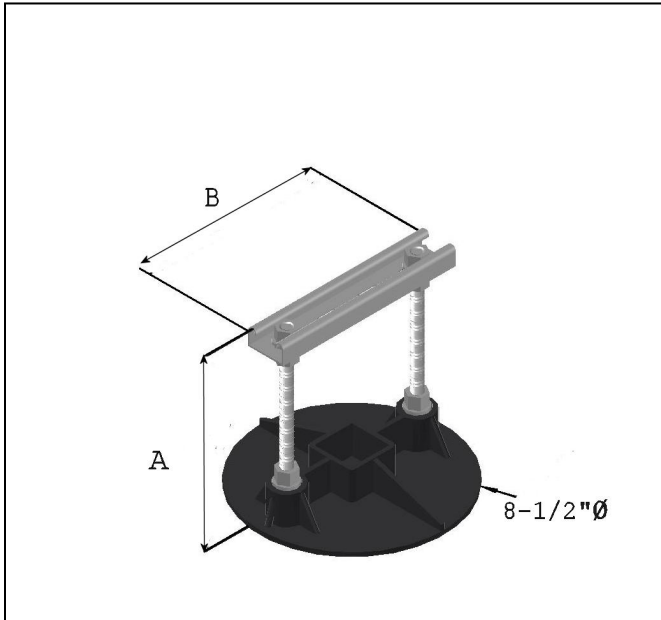

# SS500A

## Pipe Support

# Specification Sheet



**SS500A – Adjustable Pipe Support** – Is designed specifically for use on rooftop without adhesive, roof penetrations, flashings or damage to roofing system. Designed to support conduit or pipe up to  $\varnothing 4"$ . Height of channel is adjustable along the length of the 7" threaded rods. Use in connection with strut clamps or roller accessories for pipe support.



### Materials

**Support Base:** 8-1/2" circular base, injected molded polypropylene.

**Base Dimensions:** 1-1/2" H X 8-1/2" in diameter, with molded insert for square tubing and two threaded rod couplings molded in.

**LEED:** Minimum 40 % post-industrial recycled polypropylene with UV inhibitors.

**Frame:** 13/16" X 1-5/8" 12 ga. channel (ASTM A653) - available in Pre-Galvanized Zinc coated, Hot-Dip Galvanized or Stainless Steel finishes.

**Hardware:** 1/2" Threaded Rods (7" long) 1/2" Nuts and Washers available in Pre-Galvanized Zinc coated, Hot-Dip Galvanized or Stainless Steel finishes. 1/2" Rod Couplers inserts

**Accessories:** Strut Clamps: Protection Pads

Model	Dimensions		Weight
	A	B	
SS500A	7-5/8"/19.37 cm	8"/20.32 cm	3 lbs/1.36 kg

### Installation:

- Verify that roof surface is smooth and clean to extent needed to receive materials.
- Review approved final drawings to determine the locations of supports.
- Clean surfaces to receive supports removing any loose gravel and any foreign matter before setting support 17" circular bases.
- Accurately locate and align pre-fabricated pipe supports in locations specified as per approved shop drawings or as required herein and by site conditions to limit pipe and/or conduit deflection to L/240, not to exceed 10' (3m) on center. No Isolation pads are required under the 8-1/2" circular bases.
- Should the roofing manufacturer require a separation sheet between the roof and the support system, place a separation sheet or protective pad conforming to the existing roof manufacturer's system under 8-1/2" circular bases. Do not adhere to the roof system or 8-1/2" circular bases.
- Repeat until all supports supplied are installed in accordance with approved shop drawings.
- Remove any unused materials and packaging from job site.

This print/image and design and detail shown hereon is the property of Advanced Support Products, Inc. This print is furnished with the understanding that it is not to be reproduced without permission, and must be returned upon demand. All rights of design and invention are reserved by Advanced Support Products.

Patents #5816554; #6229497; #6427965; #6448497; #6578827 © 2010